

Participating Fluid Power Manufacturers & Foundations in the **FIRST 2003 Robotics Competition:**

- **SMC Pneumatics, Inc.**
- **Bimba Manufacturing Company**
- **Parker-Hannifin Corporation**
- **Clippard Instrument Laboratory, Inc.**
- **Festo Corporation**
- **Norgren**
- **Monnier, Inc.**
- **The Nason Company**
- **Wika Instruments**
- **Lord Corporation**
- **Thomas Industries**
- **Fluid Power Educational Foundation**



**The Pneumatic Manual for the
FIRST 2003 Competition**

The Advantages of Using Pneumatics in 2003

Fluid power technology encompasses both hydraulics and pneumatics. Hydraulic applications use pressurized fluids, mostly oil, while pneumatic applications use pressurized gases, mostly air. Mobile construction equipment uses a hydraulic pump mounted on the motor. The outlet of the pump is plumbed to a set of valves. Each valve is then plumbed to a cylinder. This allows you to distribute power from the engine all around the equipment. The same is true for a FIRST robot. Once you install the compressor operating one valve and cylinder combination, you've done most of the work. To add additional valve and cylinder combinations, you just tee into the pressure line and add in the additional circuit.

Weight

Compare the weight of several valves and cylinders to that of the motors, gears, belts, and chains used on some lift mechanisms and you will find the weight comparable, if not much lighter.

Simple to Design

Using pneumatics is much easier than building a motor, gear, chain and sprocket lift mechanism. Once you have reviewed the layout on page 13, you will find it very easy to build a circuit.

Adjustable Force

To adjust the force of the cylinder, all you have to do is adjust the regulator in front of it. The force is equal to the area of the cylinder piston times the pressure. Remember that the valves are rated at a minimum of 15-30psi to work properly.

Durable

All of us have problems burning up motors from time to time. You can stall an air cylinder against a load indefinitely and turn off the compressor. These are industrial grade products.

Strong

If you look at the force table on page 12, you have the option of using a small 3/4" bore cylinder at 20psi which will produce a force of around 9 pounds. If you use a 2" bore cylinder at 60 psi, you can get 180 pounds of force. As you can see, your options are wide open.

Custom Cylinders

You can now order the exact cylinder you need for the job and get them in a few days via regular UPS.

Last Minute Additions

At the last minute, you can add a cylinder and valve very quickly.

Congratulations on receiving your pneumatic kit for the FIRST 2003 competition.

This year we have worked very hard to make it easy for you to use pneumatics on your robot. We have also chosen components that match each other. Dean likes to refer to the boxes of parts that you get as 140 pounds of junk. This year, none of the pneumatic components are junk. Many of the major components have been manufactured exclusively for this year's competition.

COMPRESSOR

We have the same compressor provided by **Thomas Industries** that we had last year. The compressor will put out approximately 120psi before the **Norgren** relief valve opens. Because the compressor can produce a significant amount of vibration, we have included vibration isolation mounts donated by the **Lord Corporation**. These are in the pneumatic parts kit with the teflon tape. They can be screwed directly into the feet of the compressor. In order for these to isolate the vibration, they need to be mounted to a stiff piece of metal such as a 1/4" aluminum plate. The distance between the front feet is 3.5". The distance from the center line of these feet to the rear foot is 5.19". A spike relay should be used to control the power to the compressor. Ensure that the relay is programmed to provide "forward" power only to the compressor. Do not reverse the compressor!



Warning: The compressor head can get quite hot during extended operation.

PRESSURE SWITCH

We have pressure switches manufactured by **The Nason Company**. These switches are normally closed. The switches will open at approximately 115 psi and will not close again until pressure drops to approximately 95 psi. This will allow you to turn off the compressor once you are up to 115 psi, saving power in the battery.



TANKS

We have some great tanks from **Clippard Instruments**. They are small and may be mounted almost anywhere on your robot. The kit comes with two tanks. They should be mounted right after the compressor, before the Norgren main relief valve.



REGULATORS

Norgren has donated the primary regulator. These are relieving regulators. Assume that you extend the cylinder or the apparatus the cylinder is attached to against a wall. Then push against the wall with your robot. That would increase the pressure in the cylinder. The increased pressure will relieve out of the regulator and the cylinder will slowly retract. This regulator has a maximum output pressure of 60psi. This regulator must be placed in-line right after the tanks to limit the pressure to all working circuits to 60psi. It is adjustable and the outlet pressure may be reduced at your discretion. Look at the top of the regulator. You will note that one port extends out a little bit more than the others. It also has an arrow on it to denote the outlet of the regulator. The opposite port is the inlet. The gauge may be placed in either of the other ports. You will have to plug the other gauge port with the enclosed hex plug.

Monnier has donated the secondary regulator, which has a yellow ring around it. This is also a relieving regulator. Its purpose is to allow you to use reduced pressure if you have a use for it. This regulator must be placed after the Norgren regulator. Also, look at the top of the regulator. There is an arrow denoting the direction of flow. The gauge may be placed in either of the other ports. The Monnier bag provides you with plugs to put into the gauge ports. Make sure that you use the teflon tape so that it doesn't leak.

ELECTRIC VALVE

The **SMC** valve is called a double solenoid valve. There are two of these in the kit. If you pulse one of the solenoids to make the cylinder extend, you must then pulse the opposite solenoid to make it retract. Either solenoid may be left in the energized state. This is a great valve to use to maintain position when the power is turned off at the end of the match. If you use a single solenoid valve and the power is turned off, the valve would shift back to its original position and the cylinder will retract. A double solenoid valve would maintain its position until you turned on the opposite solenoid. One last thing--Always avoid turning on both solenoids at the same time. While this won't hurt the valve, you can not be sure which way the spool will shift.



FESTO Corporation has also supplied a single solenoid valve. You will have to assemble this valve package. ***The fittings are special and will only work with this valve! Do not attempt to thread them into any other component!*** Power is connected between the two leads that are closest together. This is accomplished by removing the single screw that holds the electrical connector on to the solenoid. As this valve is bigger you may want to use it if the cylinder you are moving needs to move at a higher speed than the others.



FLOW CONTROLS

We have flow controls donated by **SMC Pneumatics**. The purpose of a flow control is to control the speed of the cylinder when it is extending or retracting. Always mount these into the ports of the cylinders before you hook up the tubing.

Warning: Even if flow controls are used or the needle is turned out counter clockwise, the cylinder can extend very quickly. Always stay clear of any cylinder in motion.



PLUG VALVE

Parker Hannifin donated the plug valve. This valve can be used to release all the air in the system by just opening it.



BRASS FITTINGS

Parker Hannifin donated all the brass fittings. These are useful where you want to plug a port or plumb from one size port to another. It is important to note that all male threads require teflon tape to seal properly. Wrap the tape around the fitting, leaving the first two threads free of tape. This is because the threads are tapered and the tape may come loose from the first thread or so and clog up one of your valves.

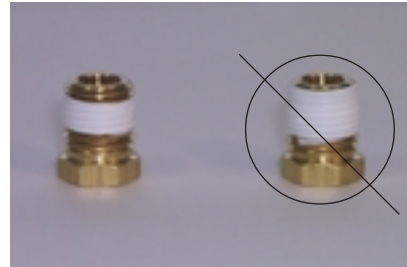

QUICK CONNECT FITTINGS

SMC Pneumatics donated the quick connect fittings. These are really easy to use. All you have to do is push the tube into the fitting. Make sure you push the tubing all the way into the fitting. To release the tubing, just push on the release button and then pull the tubing out. Don't attempt to pull the tubing without first pushing the release button.



TUBING

SMC Pneumatics has donated the tubing.

KIT CYLINDERS

We have included a cylinder from **Parker- Hannifin Manufacturing**. It is included in the kit for you to get started and understand pneumatics. Hopefully, you will find a use for it on your robot.



CUSTOM BIMBA CYLINDERS

You will be able to order custom cylinders for your robot again this year. You have a choice of 3/4" bore (diameter), 1-1/2" bore and 2" bore. You can also order the amount of stroke. (See ordering sheet) This will significantly increase your ability to design a great robot. All of the bore and stroke models are in stock and **Bimba** is ready to ship directly to your team.

***Please use great care in filling out the form when ordering. The cylinders will be shipped to the address on the order form. If the address is wrong--no cylinders will arrive at your team.**

Quantities of no charge custom cylinders will be limited to **3** per team to insure that custom cylinders will be available late in the 6 week period. In the event that you require more than three cylinders, please fax us your requirements and we will attempt to provide them as long as supplies last. Additional cylinders can also be purchased through a Bimba or Parker-Hannifin Distributor. You can find a distributor in your area by going to:

www.bimba.com/distrib/distrib.htm
or
www.parker.com/distloc/english/search.asp

How to calculate the retracted and extended length of a cylinder

Look at the drawing of the 1-1/2" bore cylinder (page 8). You will notice that the cylinder pivots about a pivot pin located in the rear of the cylinder. There is a dimension on the drawing from that pin to the back of the thread on the rod end. That dimension is "4.38 + Stroke". We will use this later. Look at the drawing of the rod clevis. There is a locking nut shown on the drawing. If you look, there is a dimension of the width that is 0.25". The locking nut threads on the rod first and is used to keep the clevis in place. Lastly, look at the dimension 1.31" on the rod clevis.

Therefore, if you thread the locking nut on the rod thread all the way to the bottom of the thread and then tighten the clevis against it, you can calculate the distance from the rear pin to the clevis pin. This is called the pin to pin distance. Assume you want to move something 8 inches. You will need to order an 8" stroke cylinder.

To find the retracting pin to pin dimension, do the following:

Base dimension	= 4.38"
Stroke	= 8.00"
Locking nut width	= 0.25"
<u>Clevis dimension</u>	<u>= 1.31"</u>
Pin to Pin Retraction	= 13.94"

To find the extended pin to pin dimension, just add the stroke:

Pin to Pin retracted	= 13.94"
<u>Stroke</u>	<u>= 8.00"</u>
Pin to Pin Extended	= 21.94"

Note: The retracted length may be somewhat longer by not tightening the clevis all the way to the end of the thread.

3/4" Bore

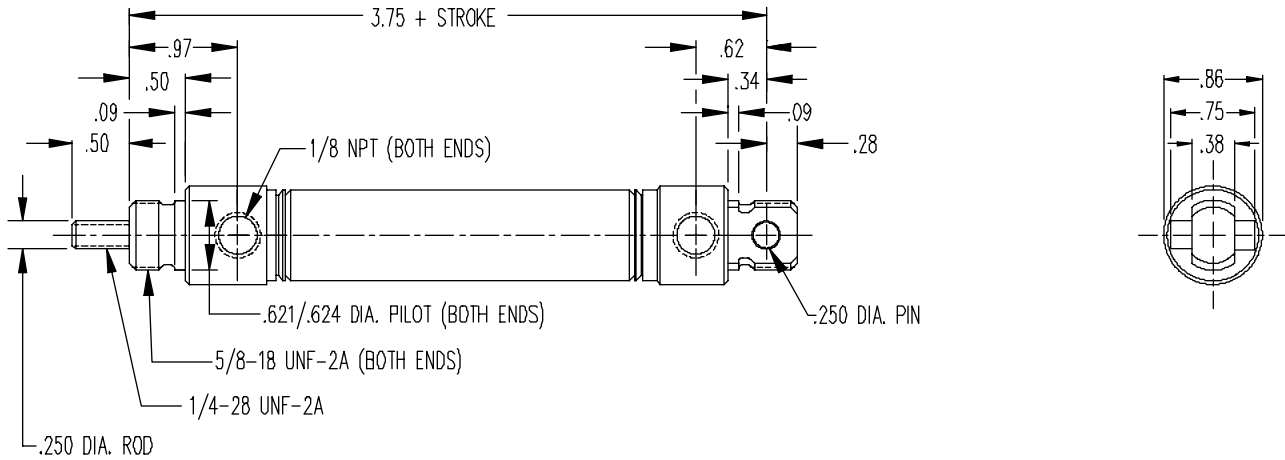

Rod Clevis

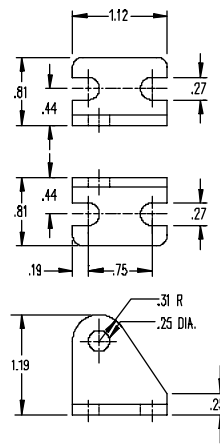
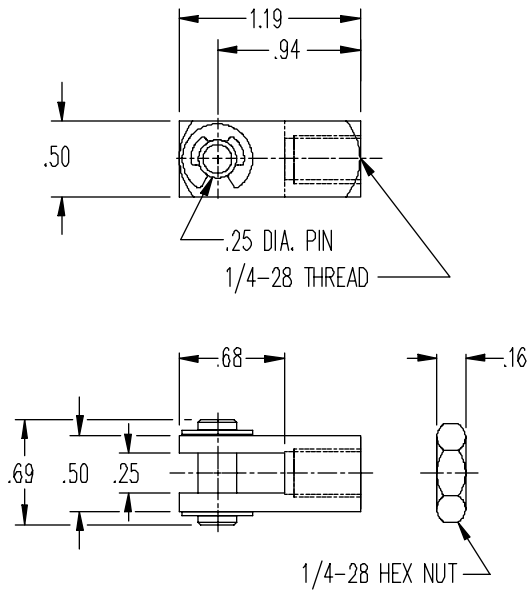

Pivot Brackets

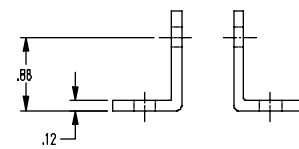

1-1/2" Bore

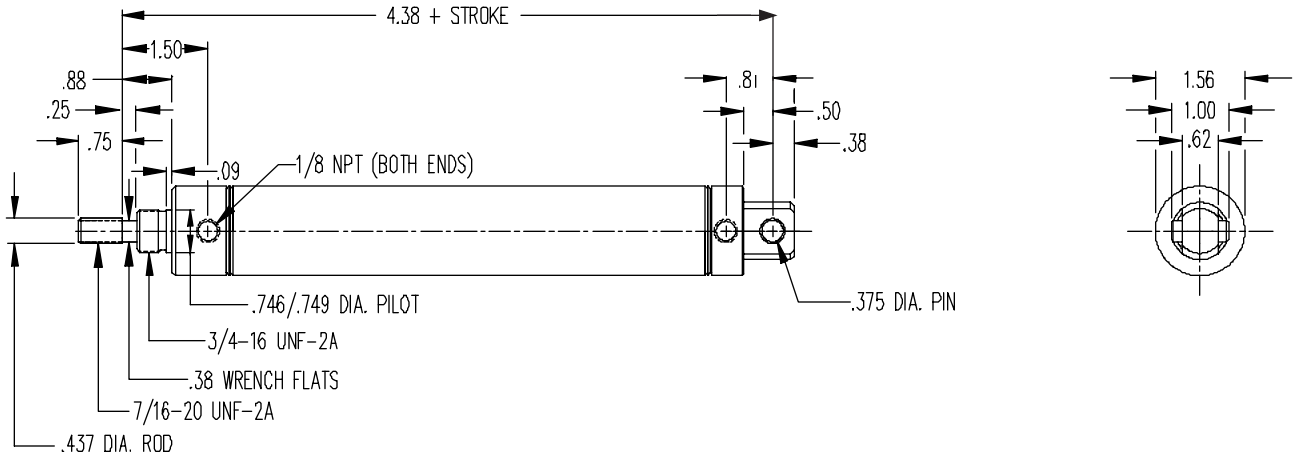

Rod Clevis

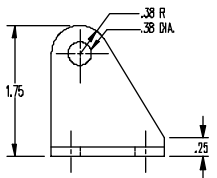
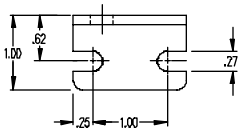
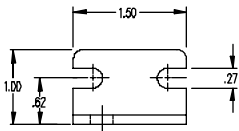

Pivot Brackets

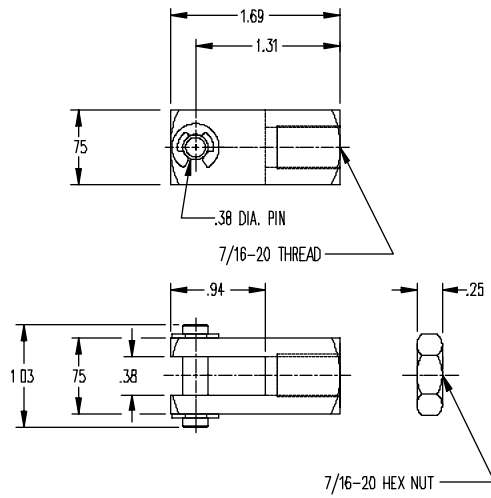
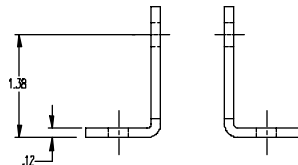

2" Bore

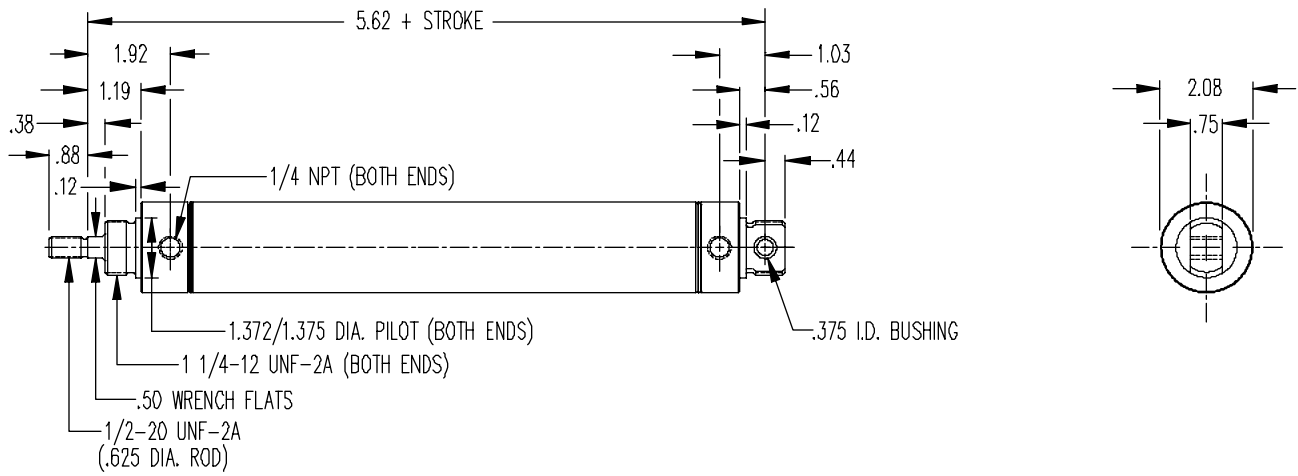

Rod Clevis

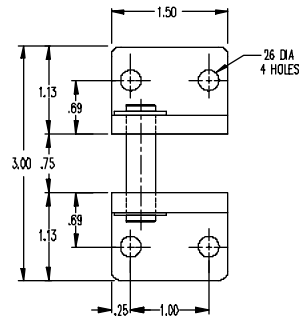
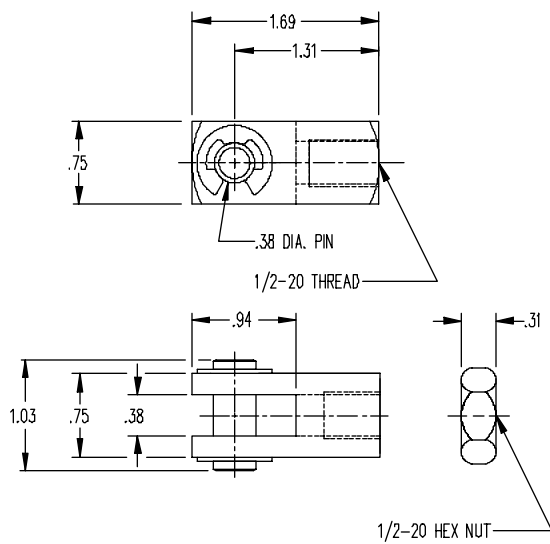

Pivot Brackets

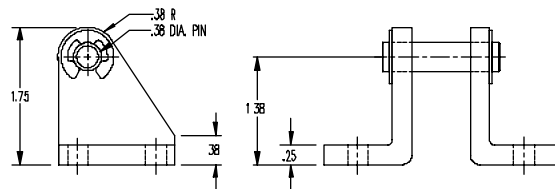

Extend and retract forces of all three bore sizes

	3/4" Bore	3/4" Bore
Pressure	Force Extended	Force Retraced
(pounds/sq. inch)	(pounds)	(pounds)
20	9	8
25	11	10
30	13	12
35	15	14
40	18	16
45	20	18
50	22	20
55	24	22
60	26	24
	1-1/2" Bore	1-1/2" Bore
Pressure	Force Extended	Force Retraced
pounds/sq. inch	(pounds)	(pounds)
20	35	32
25	44	40
30	53	48
35	62	57
40	71	65
45	79	73
50	88	81
55	97	89
60	106	97
	2" Bore	2" Bore
Pressure	Force Extended	Force Retraced
pounds/sq. inch	(pounds)	(pounds)
20	63	57
25	79	71
30	94	85
35	110	99
40	126	113
45	141	128
50	157	142
55	173	156
60	188	170

**FIRST
Pneumatic Component
Bill of Material**

Manufacturer	Quantity	Part Number	Product	Description
			Each	
Parker	1	1.50DPSR8.00	7.3 oz	Cylinder 1.5" bore x 8" stroke rear pivot mount
Parker	1	LO7131 0300	1.6 oz	Cylinder pivot bracket set
Parker	1	LO7130 0400	1.0 oz	Cylinder rod clevis
Clippard	2	AVT-32-16	14 oz	Volume Tank 2" bore by 6" length
Festo valve kit	1	MFH-5-1/8	10.6oz	Solenoid valve kit with fittings
Thomas	1	405ADC38-12	4 lbs.- 12oz	Compressor
Norgren Relief	1	16-004-015	On Compressor	120 psi relief valve
SMC Pneumatic Kit				
SMC	2	NVJ5243Y-6G-01T	3.0 oz	Double Solenoid Base Ported Valve
SMC	6	NAS2201F-N01-07S	0.6 oz	Flow Control
SMC	20	KQH07-34S	0.3 oz	Fitting, Straight 1/4 Tube
SMC	20	KQL07-34S	0.4 oz	Fitting, 90 Elbow 1/4 Tube
SMC	5	KQT-07-00-Y	0.2 oz	Fitting, Tee Union 1/4" Tube
SMC	5	KQY07-34S	0.5 oz	Fitting, Male Run T 1/8 NPT ~1/4 Tube
SMC	1	TIUB07B-20	1#	1/4" OD tubing - 20 meters
Parker Brass Kit				
Parker	1	PV609-2	2.4 oz	Manual 2-way plug valve
Parker	4	2203P-2	1.3 oz	Union Tee
Parker	6	222P-4-2	1.1 oz	Adapter 1/4" female to 1/8" male
Parker	6	216P-2	0.4 oz	Hex nipple 1/8"npt
Parker	12	209P-4-2	0.4 oz	Bushing 1/8" female to 1/4" male
Parker	6	218-2	0.3 oz	Plug 1/8"
Parker	6	218-4	0.7 oz	Plug 1/4"
CFH Robotics LLC kit				
Lord Corp	1	SMB003-0100-2	0.3 oz	Vibration isolators for compressor
Nason	1	SM-2B-115R	2.1 oz	Pressure switch opens @ 115psi/closes @ 95psi
Norgren	1	R07-153-RNEA	4.7 oz	Main regulator w/60psi max output
Norgren	3	18-013-212	1 oz.	0-160 psi gauge for Norgren regulator
Norgren	1	18-025-003	0.7 oz	Regulator mounting bracket and nut
Monnier	1	101-3002-1	3.2 oz	Secondary pneumatic regulator
Monnier	1	13536	1.2 oz	Regulator mounting bracket and nut
Wika	2	0-160 psi	2.9 oz	Gauge
Teflon tape	1			1/4" by 100"
Approximate weight calculations for custom clinders, not including the rod clevis or pivot brackets:				
3/4" Bore	0.21 lbs. + 0.03 lbs. per inch of stroke			
1/2" Bore	0.73 lbs. + 0.08 lbs. per inch of stroke			
2" Bore	1.62 lbs. + 0.15 lbs. per inch of stroke			

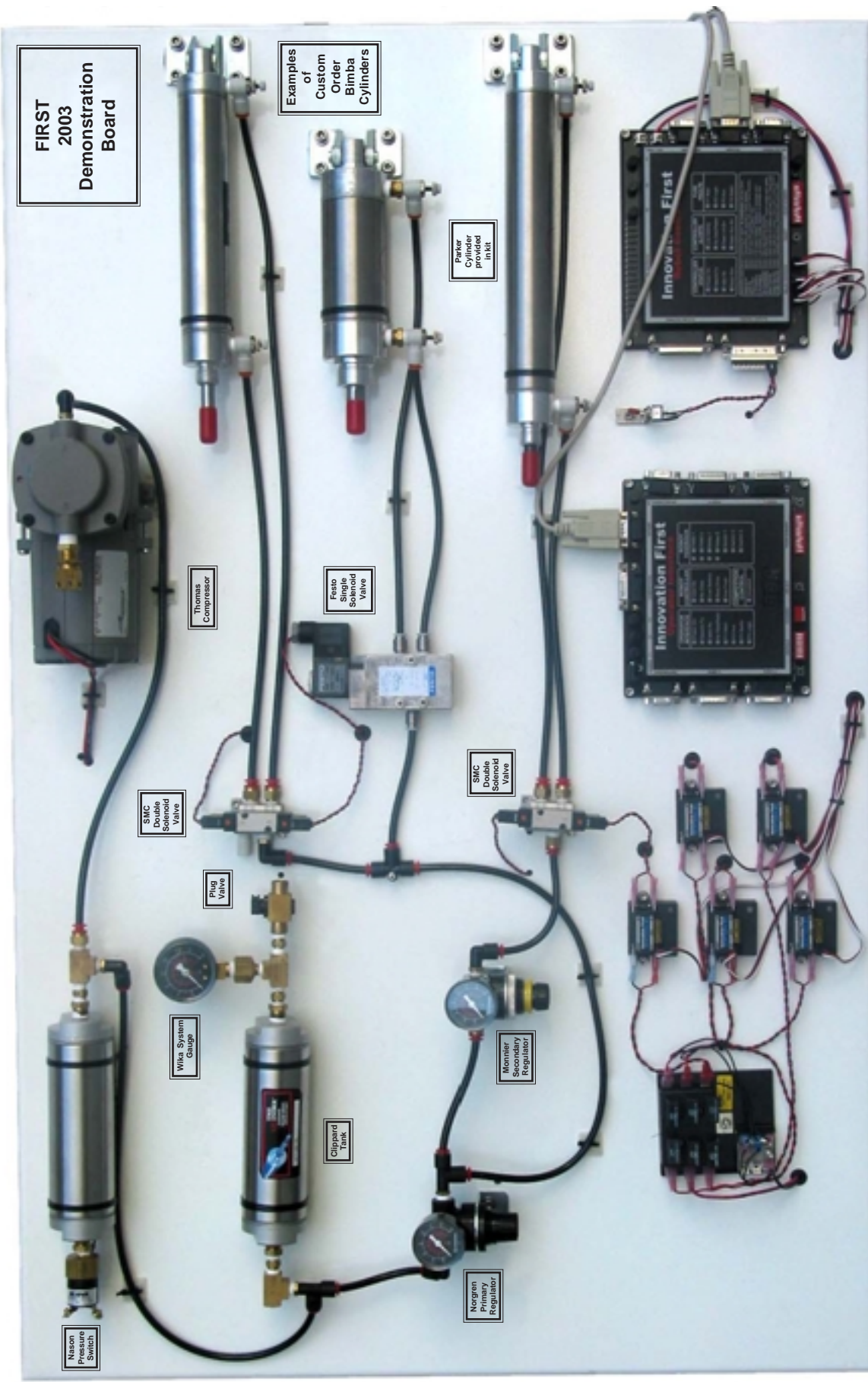

FIRST 2002 Demonstration Board

The following companies provided product for the 2003 Competition:

Bimba Manufacturing
Clippard Instrument Laboratory, Inc.
Festo
Nason Corporation
Lord Corporation
Monnier, Inc.
Norgren
Parker Hannifin, Inc.
SMC Pneumatics, Inc.
Thomas Industries, Inc.
Wika Instrument

Web Sites for Product Suppliers and Foundations

Bimba Manufacturing	- www.bimba.com
Clippard Instrument Laboratory, Inc.	- www.clippard.com
Festo	- www.festo.com
Lord Corporation	- www.lordmpd.com
Monnier, Inc.	- www.monnier.com
Nason Company	- www.nasonptc.com
Norgren	- www.norgren.com
Parker Hannifin, Inc.	- www.parker.com
SMC Pneumatics, Inc.	- www.smcusa.com
Wika Instruments	- www.wika.com
FPEF	- www.fpef.org

FIRST Custom Cylinder Order Form

Team # _____

Team Name: _____
 School: _____
 Corp. Sponsor: _____

For Order Confirmation

Person Ordering: _____
 Phone Number: _____ Fax Number: _____
 E-Mail Address: _____

Shipping Information

School / Business: _____
 Attn: _____
 Address: _____
 City: _____
 State: _____ Zip: _____

Bore Size	1/2"	1"	1-1/2"	2"	2-1/2"	3"	4"	5"	6"	7"	8"	9"	10"	11"	12"
3/4" Bore										N/A		N/A		N/A	N/A
1-1/2" Bore															
2" Bore														N/A	

*All cylinder orders include clevis, jam nut and pivot brackets.

FAX ORDER TO THIS NUMBER: 954-429-9515

Order Inquiries: first@hpeco.com **Technical Help:** fhord@hpeco.com
Emergency Only--Phone: 954-429-9560 **Back-Up Fax Number:** 954-429-0858

*** Important ***

Each team is responsible for express shipping charges! If you don't have your own freight account--please fill out credit card information; otherwise, cylinders will ship **UPS/Ground!** *Please Note:* All teams outside of continental US will have air freight charges.

Preferred Shipping Method

- Fed-Ex - Acct #: _____ Next Day Second Day
 Airborne Exp - Acct #: _____ Next Day Second Day
 UPS - Acct #: _____ Next Day Second Day

Credit Card Information

Credit Card: Visa Master Card Am. Express **Exp. Date:** _____ **Team#:** _____
Acct. Number: _____
Name on Card: _____